



**intec**  
C O P P E R



## **The Intec Copper Process**

### **Superior and Sustainable Copper Production**

Enquiries should be directed to:

Mr. A. John Moyes  
Technical Director  
Intec Ltd  
Gordon Chiu Building, J01  
Department of Chemical Engineering  
Maze Crescent  
University of Sydney NSW 2006  
AUSTRALIA

Telephone: +612 9351 6741  
Facsimile: +612 9351 7180  
Email: [john@intec.com.au](mailto:john@intec.com.au)  
Website: [www.intec.com.au](http://www.intec.com.au)

## **The Intec Copper Process is a Proven Hydrometallurgical Process for the Treatment of Copper Sulfide Concentrates**

The Intec Copper Process is a proven, patented hydrometallurgical process for the extraction of pure copper and precious metals from sulfide concentrates.

The process is based on the electrolytic deposition at the cathode of LME (London Metal Exchange) Grade A purity copper from a purified sodium chloride-sodium bromide electrolyte. During electrowinning, the mixed halide species  $\text{BrCl}_2^-$  ("Halex™") is generated in solution at the anode and exhibits powerful leaching characteristics when it is re-circulated to treat incoming concentrate feed.

The Intec Copper Process has been developed and proven over the last ten years at a cost of US\$16 million. Development commenced at bench scale, progressed through to a continuous 50kg-Cu per day pilot plant and was subsequently proven in a 350tpa-Cu demonstration plant. Accordingly, design methodologies, materials of construction and process control have all been validated. Following a thorough review, H.G. Engineering of Toronto, Canada, have concluded that the Intec Copper Process is suitable for commercial application.

## **The Intec Copper Process is Superior to Smelting and Other Hydrometallurgical Processes**

The Intec Copper Process has a clear advantage over smelting<sup>1</sup> and other hydrometallurgical processes, through a combination of:

- significantly lower operating and capital costs;
- economic viability at capacity levels as low as 15,000tpa-Cu;
- production of an environmentally acceptable residue;
- recovery of precious metals in the copper leach circuit;
- tolerance to low grade and "dirty" concentrates;
- ability to treat all copper sulfide minerals, including chalcopyrite and enargite;
- low energy consumption;
- no liquid emissions;
- no production of noxious gases; and
- mild operating conditions of low temperature and atmospheric pressure.

Smelting has been incrementally improved over time to a sufficient extent for it to remain the preferred process for the treatment of copper sulfide concentrates. However, smelting remains burdened by several major disadvantages:

- high capital cost;
- unprofitable at small scale;

- the generation of sulfur dioxide, which requires conversion to sulfuric acid at additional cost;
- high penalties for the treatment of low grade and "dirty" concentrates; and
- a general perception as a dirty, environmentally unfriendly process.

A number of hydrometallurgical processes have been developed as an alternative to smelting but, with the exception of the Intec Copper Process, none have demonstrated a sustainable competitive advantage over smelting.

The other hydrometallurgical processes can be categorised as either biological leach processes or pressure leach processes. Regardless of the leach method, all of these processes include a solvent extraction – electrowinning ("SX-EW") circuit. Hence, the economics of these hydrometallurgical processes can never exceed those of the core SX-EW step. Furthermore, all of these processes are unable to recover precious metals without cyanide leaching of the residue, thus further limiting their economic potential.

Uniquely among hydrometallurgical processes, the Intec Copper Process combines;

- the direct recovery of precious metals<sup>2</sup>;
- the production of pure copper without utilising solvent extraction;
- the rejection of sulfur in elemental form;
- operating conditions of atmospheric pressure and low temperature; and
- no requirement for pure oxygen.

Therefore, the Intec Copper Process has significantly lower operating and capital costs than both smelting and other hydrometallurgical processes. This economic advantage is sustained at capacities as low as 15,000tpa-Cu, thereby increasing the attractiveness of minesite metals production.

In summary, the wide-ranging and demonstrable advantages of the Intec Copper Process position it to become the industry's "process of choice".

## **The Intec Copper Process is Economically Superior to all Other Processes**

The most compelling advantage of the Intec Copper Process is its economic superiority over smelting and other hydrometallurgical processes, as shown in *Figures 1 & 2* on page 2. The economic comparison contained in these figures is based on independent analysis undertaken by Prof. David Dreisinger of the University of British Columbia, Canada ("Dreisinger analysis")<sup>3</sup>.

<sup>2</sup> 80% of copper concentrates contain commercial levels of precious metals.

<sup>3</sup> David Dreisinger, "Emerging Options for the Hydrometallurgical Treatment of Copper Concentrates: A Review of Technical and Financial Feasibility", 1998.

<sup>1</sup> The term smelting as used in this document is inclusive of the subsequent refining stage.

The Dreisinger analysis was based on the development of conceptual mass balances for each of the processes reviewed from which operating and capital costs were estimated. This approach ensured a consistent basis for comparison and included the following key assumptions:

- a plant capacity of 100,000 tpa-Cu;
- the treatment of a 25% Cu concentrate feed containing no precious metals; and
- power costs of US6.25¢/kWh.

Intec has separately included in the Dreisinger analysis the capital and operating costs of a precious metal recovery circuit for the other hydrometallurgical processes reviewed. This addition has been undertaken in order to provide a more meaningful comparison with the Intec Copper Process<sup>4</sup>. The basis for comparison is on-site production costs and therefore excludes marketing and freight costs and acid credits, whilst the cost of acid neutralization is included.

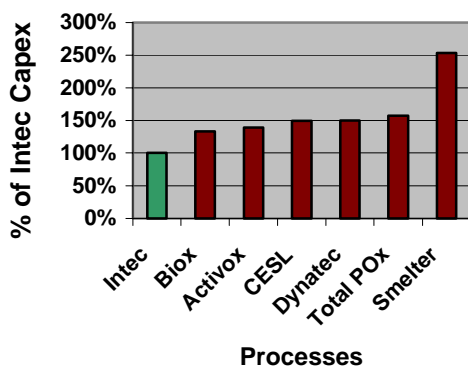

**Figure 1:** Comparison of capital costs at 100,000tpa-Cu plant capacity for competing processes.

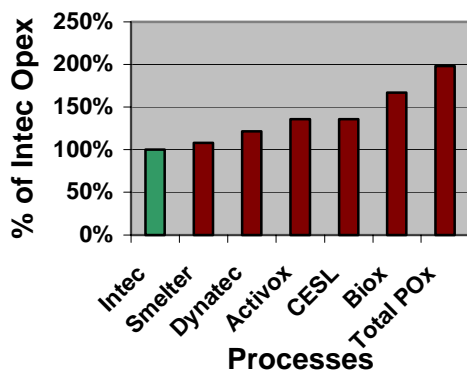
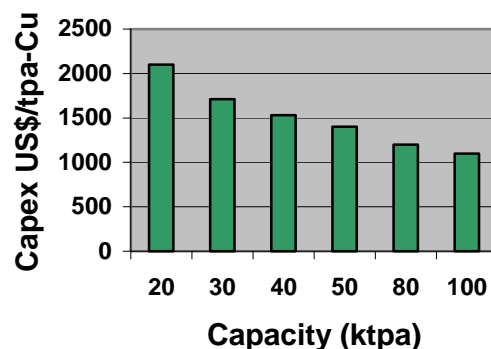

**Figure 2:** Comparison of operating costs at 100,000tpa plant capacity for competing processes.

In 1999, H.G. Engineering undertook a detailed capital cost and operating cost estimate for a 50,000tpa-Cu Intec Copper Process plant located in southwestern United States. In determining capital

cost estimates, H.G. Engineering first specified a detailed equipment list and then obtained quotes from equipment suppliers.

H.G. Engineering's capital cost estimate was US\$70.5 million or US\$1,410 per annual tonne of copper production. Using this study as a basis, capital and operating costs have been estimated for a range of Intec Copper Process plant sizes as shown in Figures 3 & 4.



**Figure 3:** Effect of plant size on capital cost of the Intec Copper Process (based on H.G. Engineering cost estimate).

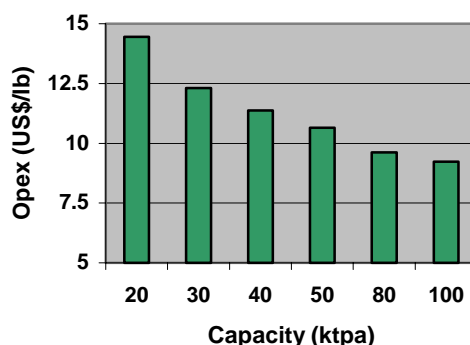

**Figure 4:** Effect of plant size on operating cost of the Intec Copper Process (based on H.G. Engineering cost estimate).

The economic competitiveness of the Intec Copper Process provides small and remote mines with the option of on-site metal production. This development option results in the elimination of onerous costs for concentrate transportation and treatment. In Table 1 on page 3, the economics of a dedicated on-site 50,000tpa-Cu Intec Copper Process plant are compared with the economics of treating a 28%<sup>5</sup> Cu concentrate through a custom smelter at a tidewater location.

<sup>4</sup> Precious metals are routinely recovered in the Intec Copper Process, whilst other hydrometallurgical processes require as a minimum a lime-boil for silver recovery and a cyanide circuit for gold recovery.

<sup>5</sup> This represents a world average for chalcopyrite concentrates.

Item	Smelter (US¢/lb)	Intec Copper (US¢/lb)
Concentrate Transport (US\$60/dmt)*	9.5	0
Treatment Charge (US\$90/dmt)**	14.5	0
Refining Charge (US9¢/lb-Cu)**	9	0
Intec Copper Operating Cost***	0	10.5
Payable Metal Differential†	N/A	(1.3)
Intec Copper Capital Service Charge††	0	7.5
Product Marketing and Freight	0	4.0
Merchant Premia for Billet	0	(2.5)
<b>Total</b>	<b>33</b>	<b>18.2‡</b>

\* Average transport charge from remote location in Australia. Source: Brook Hunt, "Copper Costs, Mines and Projects" 2001.

\*\* Long term forecast of sustainable contract rate. Source: Brook Hunt, *ibid*.

\*\*\* Assumes power cost of US5¢/kWh for remote location.

† Custom smelters pay 96.5% for Cu content in concentrate, while the Intec Copper Process recovers 98% of Cu in concentrate. Estimate assumes copper price of US\$0.85/lb.

†† Capital service charge over 15 years at a 7.5% real interest rate.

‡ Excludes royalty for use of Intec Copper patent.

**Table 1:** Cost comparison between a dedicated on-site Intec Copper Process plant and treatment of copper concentrate from a remote source through a custom smelter at a tidewater location.

As shown above, at 50,000tpa-Cu the Intec Copper Process reduces the cost to metal by some 13.5US¢/lb. Furthermore, this analysis excludes the benefit gained from improved precious metal recovery from using the Intec Copper Process by comparison with a custom smelter. In addition, unlike smelters, the Intec Copper Process does not levy charges for penalty elements present in concentrate feed. These matters are concentrate specific and hence the additional benefits from using the Intec Copper Process, beyond those identified above, will vary among individual concentrates.

The Intec Copper Process also has the potential to reduce both mining and milling unit costs through its ability to treat concentrates grading as low as 18% copper at minimal additional cost. Therefore, project economics can be further enhanced through:

- higher mill recoveries as a result of producing lower grade and/or contaminated concentrates; and

- expansion of the reserve inventory through reductions in cut-off grade.

### The Intec Copper Process is Ready for Commercial Application

The development of the Intec Copper Process has focused on achieving maximum operational experience with its chemistry, equipment and materials of construction. The total cost of this development program has amounted to some US\$15 million over a period of ten years, and has comprised:

- bench-scale testing;
- operation of a 50kg-Cu/day pilot plant; and
- operation of a 350tpa-Cu demonstration plant.

The validation of the Intec Copper Process through the extensive development program has progressed it to the stage where it is now available for commercial application. Comprehensive reviews of the Intec Copper Process by respected authorities have consistently confirmed both its technical feasibility and economic viability<sup>6</sup>.

### Significant Operating Experience has been gained with the Intec Copper Process

After initial bench-scale and mini pilot plant work, practical operational experience was gained with the Intec Copper Process in two distinct stages.

The first stage was the continuous 50kg-Cu/day pilot plant (see Figure 5), which operated for an aggregate of 290 days during the period August 1994 to November 1995. As a result, by November 1995, the Intec Copper Process had been demonstrated to perform satisfactorily.



**Figure 5:** Intec Copper pilot plant.

<sup>6</sup> These have included H.G. Engineering, Kvaerner Davy, Behre Dolbear, The Winters Company and Prof. David Dreisinger. These groups have individually confirmed either technical feasibility, economic viability or both.

The pilot plant achieved copper extractions up to 99.5%, gold extractions up to 95%, and silver extractions up to 99% from five different concentrate feeds (Cobar, Mt Lyell, Neves Corvo, Northparkes and Ok Tedi). Current efficiencies in the electrowinning circuit up to 98% were achieved; and the leach residue proved to be stable, and hence disposable – in accordance with the Toxicity Controlled Leach Procedure (TCLP) test as approved by the New South Wales Environmental Protection Authority (“EPA”).

In summary, the pilot plant demonstrated the potential of the Intec Copper Process and provided the justification for proceeding to the next stage of development.

This next stage consisted of the construction and operation of a 350tpa-Cu demonstration plant at a project cost of US\$10 million. The plant operated from August 1998 to May 1999 on a blend of concentrates from Cobar, Neves Corvo and Northparkes.

As a result of demonstration plant operations:

- a thorough understanding of process chemistry and process control was achieved;
- materials of construction for a commercial plant were specified;
- the environmental acceptability of residue for disposal to landfill was demonstrated; and
- marketable copper product was produced and sold to a domestic copper fabricator.

## Description of the Intec Copper Process

The patented Intec Copper Process was developed for the recovery of copper at LME Grade A purity from sulfide concentrates. Essentially, the Intec Copper Process consists of the three sequential circuits of leaching, purification and electrowinning. A simple flow diagram for the Intec Copper Process is shown in *Figure 6*. The leach section is a three stage countercurrent configuration with concentrate fed to stage 1 and oxidant fed to stage 3. Purification consists of cupric reduction, silver removal and alkali precipitation. Electrowinning consists of the recovery of copper metal and the simultaneous regeneration of the leach liquor (lixiviant).

### Electrowinning

Electrowinning is at the heart of the Intec Copper Process, with LME Grade A purity copper metal being electrowon from a purified electrolyte at 1,000 A/m<sup>2</sup> current density in a unique electrowinning cell (see *Figure 7*).

Electrolyte, principally comprising 250 gpl sodium chloride (NaCl), 28 gpl sodium bromide (NaBr) and 75 gpl cuprous (Cu<sup>+</sup>) ion, is fed to the cathode compartment of the diaphragm cell where 50 gpl copper is stripped by the formation of copper dendrites at the cathode. The spent catholyte passes through a porous diaphragm (filter cloth) to the anode compartment where the residual 25 gpl cuprous is oxidised to cupric, with the remaining energy being consumed in the production of the bromo-chlorine oxidant (BrCl<sub>2</sub><sup>-</sup>). Reactions at the anode thus regenerate the oxidising strength of the electrolyte, which is returned to the leach. The oxidant, BrCl<sub>2</sub><sup>-</sup>, is referred to as Halex™.

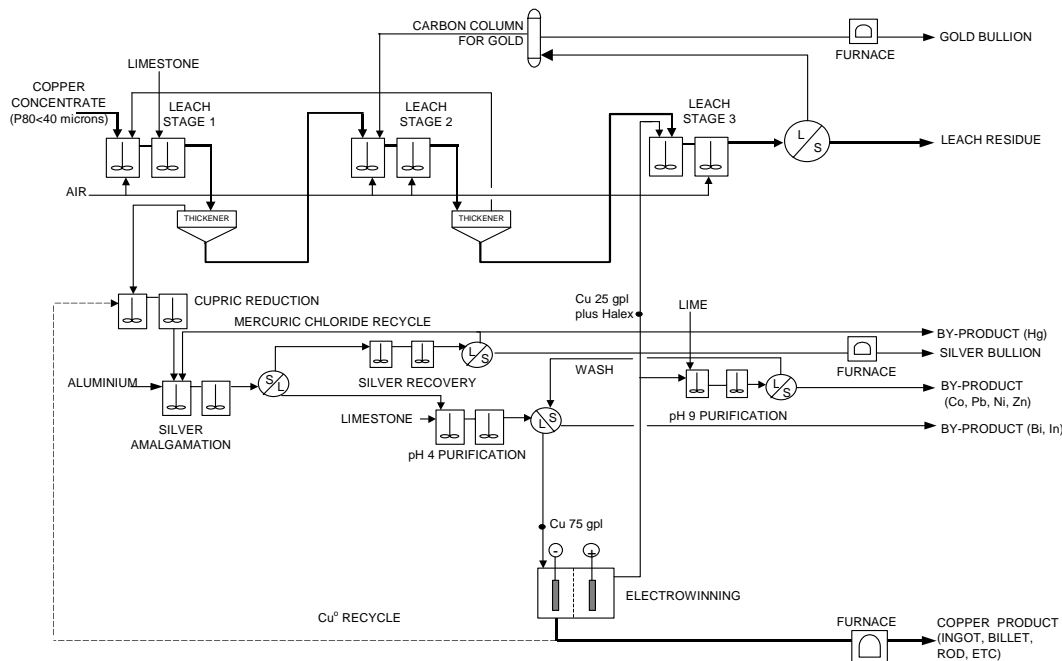

**Figure 6:** Intec Copper Process flow diagram



**Figure 7:** *Electrowinning cell (foreground) and rectifier (background) in full production at the Intec Copper Process demonstration plant.*

#### *The Lixiviant*

The Halex™ laden lixiviant, generated at the anode, is the most significant of the various unique aspects of the Intec Copper Process. It represents a simple method for storing a powerful oxidising agent in soluble form, whereas previously, chloride-based technologies operating at similar oxidizing potential have produced chlorine gas. This lixiviant is at an oxidation potential (Eh) of 1,000 mV (all Eh values are relative to Ag/AgCl), which readily leaches gold. It is this liquor that is used for the leaching of copper sulfide concentrates.

#### *Extraction*

The leach circuit operates at 85°C with oxygen supplied by air at atmospheric pressure.

Copper concentrate ground to P<sub>80</sub> 40 microns is fed to stage 1 of the leach (see Figure 8), and then progresses through the circuit to stage 3. Copper extraction is typically 98.5% and is achieved with a leach residence time of 12 to 14 hours. The fresh Halex™ lixiviant from the anode is fed to stage 3, increasing its tenor as it progresses through the leach circuit, eventually exiting stage 1 as 75 gpl copper primarily in the cuprous form.



**Figure 8:** *Leach Stage 1 (right foreground) at the Intec Copper demonstration plant*

Gold is dissolved in stage 3 at an Eh of 550 to 650 mV and adsorbed onto a carbon filter, from which it is subsequently recovered.

The leach residue is separated and washed in a filter press before discharge to either a landfill or a tailings dam. Any arsenic that is present in the concentrate is contained in the solids residue in the benign ferro-arsenate form.

The pregnant liquor leaves the leach circuit containing a number of impurities, such as cobalt, nickel, indium, mercury, silver, zinc and lead, which readily leach from the concentrate feed.

#### *Purification*

The pregnant electrolyte is purified in a three-stage system prior to electrowinning (see Figure 9). The first stage involves the conversion of any residual cupric ion to cuprous (by passing the pregnant electrolyte over copper dendrites) to condition it for the remaining two stages of purification.

The second stage involves the addition of soluble mercury and aluminium to the pregnant liquor. The aluminium forms a ‘copper sponge’, which provides a large surface area that enables the silver to be galvanically removed from the liquor as an amalgam. The amalgam is subsequently treated to produce soluble mercury for recycle to the front of the circuit and a silver bullion by-product.

In the third stage, impurities such as residual iron, indium, and bismuth are precipitated at pH 4.0-4.5 by the addition of ground limestone.

The resultant purified copper solution is then sent for electrolysis as described earlier, in order to produce high purity copper metal and regenerate the lixiviant for recycle to the leach section.



**Figure 9:** *The purification circuit at the Intec Copper demonstration plant, with cupric reduction in the foreground, and pH4 purification in the background*

A separate bleed stream takes a small flow of electrolyte (at minimum copper tenor) from the electrowinning cells, and treats it to remove zinc,

lead, cadmium, cobalt, manganese, magnesium and nickel as solid precipitates with the liquor returning to the process. These metals have no effect on product purity and thus may be removed after electrowinning.

**The Intec Copper Process Produces Copper Metal in the form of Copper Dendrites**

Primary copper product is in the form of dendrites (see Figure 10) that are washed and dried under inert atmosphere.

Dendrites are a versatile form of copper product that do not have the materials handling limitations of conventional cathode product. Unlike conventional cathode, dendrites can be either pneumatically conveyed, pumped as slurry, or briquetted.

However, typically the dendritic copper product is melted in an electric induction furnace, from which it is subsequently cast into forms that satisfy downstream customer requirements. This is generally as ingot or billet, but significantly higher value-added products such as rod can be beneficially produced considering that the copper is already in the molten state. The specification of the Intec Copper product is detailed below in Table 2.



**Figure 10:** Copper dendrites growing on the cathode.

**The Intec Copper Process is Environmentally Sustainable**

*No Liquid Effluent and Benign Gaseous Emissions*

The Intec Copper Process is inherently environmentally sustainable because it is based on a non-toxic brine lixiviant. There is no liquid effluent, and only benign gases in the form of spent air and water vapor are produced.

*Stable Solids Residue*

The residue generated by the leach process (see Figure 11) consists of gangue minerals plus chemically generated elemental sulfur and haematite. The electrolyte composition inhibits the formation of jarosite.

If commercially desirable, the sulfur can be separated from the residue, whilst the haematite, a stable iron oxide, is known to stabilise heavy metals.

Arsenic from the concentrate feed is stabilised in the residues as ferro-arsenate.



**Figure 11:** Environmentally acceptable leach residue ready for landfill.

The residue produced is suitable for landfill. Operations at the Intec Copper demonstration plant saw all of the residues pass the EPA's TCLP test for solid wastes, with the majority passing inert waste classification.

Classification	Element	LME Max Concentration (ppm)	Intec Copper Product (ppm)
Group 1	Se	2	<0.1
	Te	2	<0.1
	Bi	2	<0.1
Group 1 Total		3	<0.3
Group 2	Cr		<0.1
	Mn		<0.1
	Sb		<0.1
	Cd		<0.1
	As		<0.1
	P		<0.1
Group 2 Total		15	<0.6
Group 3	Pb	5	2
Group 4	S	15	7
Group 5	Sn		<0.1
	Ni		<0.1
	Fe	10	2
	Si		<0.1
	Zn		1
	Co		<0.1
Group 5 Total		20	<3.3
Group 6	Ag	25	15-20

**Table 2:** Intec Copper product specification

### *Favourable Life Cycle Analysis*

To expand the understanding of the environmental aspects of the Intec Copper Process, a life cycle analysis was undertaken by Sydney University with contributions by the leading environmental consulting firm, ERM (Environmental Resources Management), and ANSTO (Australian Nuclear Science and Technology Organisation). The combined studies provided strong support for the expectation of long-term stability for the residue.

### *Low Energy Consumption*

The ability to electrowin copper from its cuprous state is a key advantage of chloride systems when compared to sulfate systems. Although 1000A/m<sup>2</sup> current density is applied in the Intec Copper Process, energy consumption is relatively low at 1650kWh/t-Cu (1435kWh/t-Cu excluding recycle). This compares to 1900-2100kWh/t-Cu for sulfate systems.

Another key advantage of the Intec Copper Process is the ability to leach copper at relatively mild conditions. This permits air to be used rather than oxygen. Furthermore, the formation of elemental sulfur during leaching significantly reduces the oxygen requirement when compared to other processes where sulfate formation is substantially higher. Finally, high metal extractions are achieved without the need for ultra fine grinding.

To examine the effect of these advantages versus other copper processing technologies, the Commonwealth Scientific and Industrial Research Organisation (“CSIRO”) performed a life cycle analysis in 2001 with an emphasis on Global Warming Potential (GWP), Acidification Potential (AP) and total energy consumption<sup>7</sup>. The study concluded that:

*“In conclusion, based on data provided by Intec Ltd and that sourced from the literature, and bearing in mind the assumptions and approximations made in relation to these data, this LCA study has shown the Intec Copper Process to have the lowest environmental impact in terms of Global Warming Potential (GWP), Acidification Potential (AP) and total energy consumption of all the hydrometallurgical processes considered. This advantage is extended further as the concentrate grade decreases and at very low concentrate grades (in the order of 15% Cu) even includes the flash smelting process.”*

Figure 12 below shows a comparison of the total energy consumption of the Intec Copper Process against other hydrometallurgical process and smelting as determined by the CSIRO.

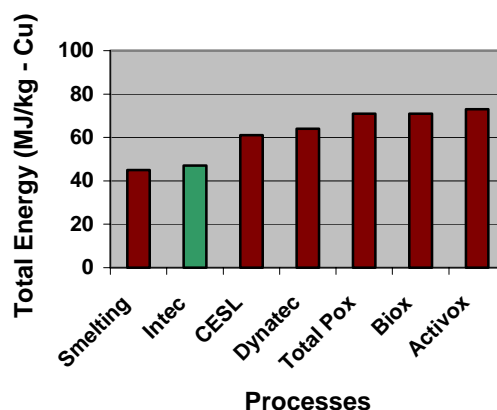

**Figure12:** Comparison of total energy consumption from CSIRO LCA.

### **The Intec Copper Process will become the Industry’s future ‘Process of Choice’**

There is increasing interest by copper industry participants in the use of hydrometallurgical processes for the production of copper metal from sulfide concentrates. This is a consequence of the realisation that hydrometallurgy represents a viable and advantageous alternative to smelting.

The Intec Copper Process has the lowest capital and operating costs of all proposed hydrometallurgical processes for the production of copper metal from sulfide concentrates. Furthermore, the Intec Copper Process is environmentally sustainable and offers the potential to generate economic savings in mining and milling activities.

As the Intec Copper Process has a clear sustainable advantage over smelting and other hydrometallurgical processes, it is set to become the industry’s **“Process of Choice”**.

<sup>7</sup> Norgate, T. A Comparative Life Cycle Assessment of Copper Production Processes, CSIRO Report DMR-1768, Oct. 2001